

Temperature sensor type CT C, CT C1, CT C2, CT C3

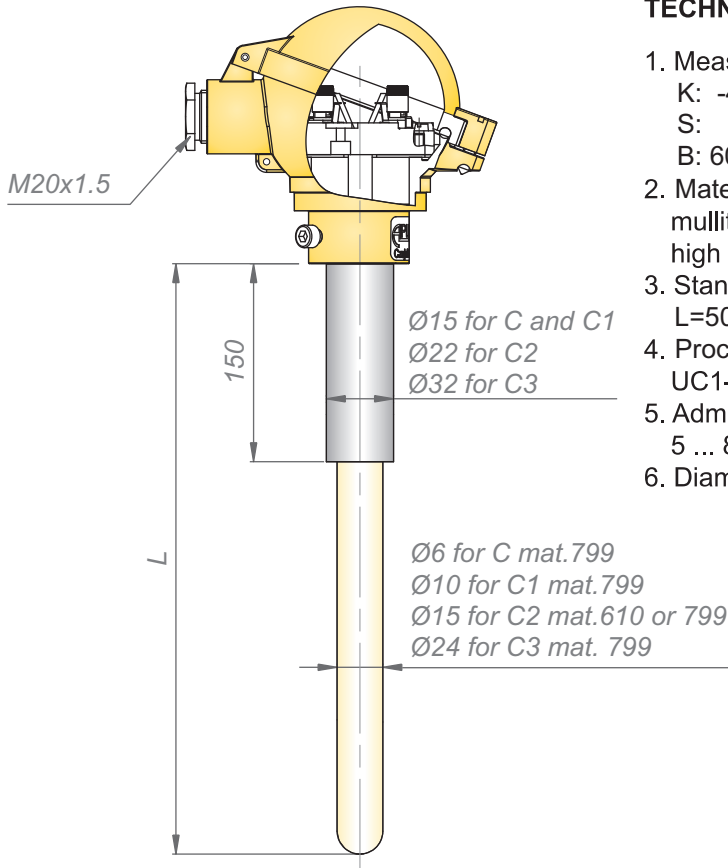

TECHNICAL DATA:

1. Measuring range (constant/momentary)
 K: -40...1000°C / 0...1100°C
 S: 0...1300°C / 0...1600°C
 B: 600...1600°C / 660...1700°C
2. Material of wetted parts:
 mullite ceramic material 610
 high aluminium ceramic material 799
3. Standard immersion length
 L=500, 700, 1000, 1400 mm (*)
4. Process connection:
 UC1-15, UC2-15, UC1-22, UC2-22
5. Admissible vibrations at mounting site:
 5 ... 80 [Hz] up to 2 [g]
6. Diameters of thermoelectric wires:

Type	Ø [mm]
K	1 for C and C1 1.6 for C2 and C3
S	0.35 or 0.5
B	0.35 or 0.5

Ordering procedure:

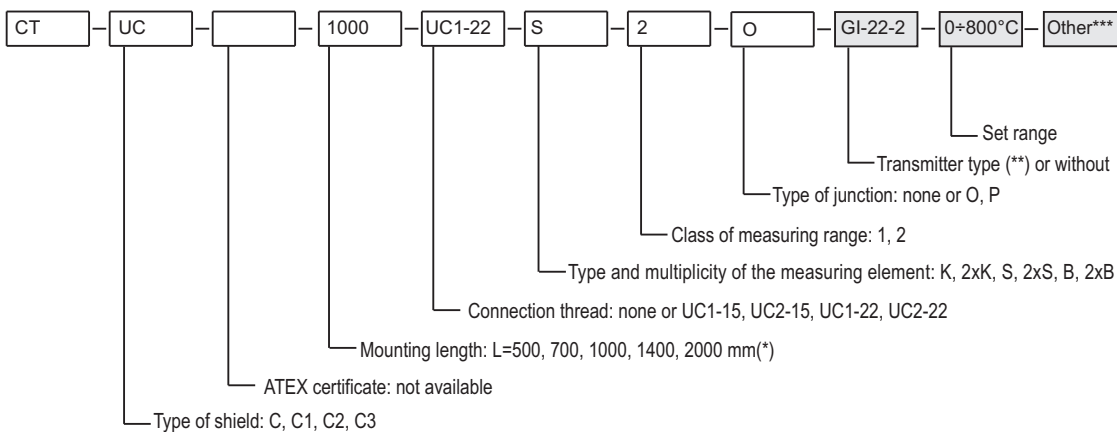

ADDITIONAL INFORMATION:

1. Type of exchangeable insert: W4.
- 2.(*) Non-standard version of temperature sensors on request.
- 3.(**) Type of temp. transmitters: GI-22-2 or other.
- 4.(***) Additional required parameters acc. to transmitter data sheet.